

Technical Data

Cage size useful dim. (m) L x W x H 1,3 x 0,9 - 1,5 X 1 (*)		Max Payload 500 kg	Ground dimensions (m) 1,7 X 1,5 (*)		Max. working height (m) 100 (*)
Mast section dim.(mm) 400 x 393 x 1489	Mast section weight (Kg) 40	Tie In distance (m) 6	Electrical supply (*)	400 V 50 Hz	Treephase
				220 V 50 Hz	Single phase
				460 V 60 Hz	Treephase
Model	VFC (Inverter)	Max. Speed (m/min)	Motors power (Kw)	Nominal current absorption (Amp)	Start Up Current absorption (Amp)
PH5 SINGLE PHASE	YES	12	3	11,6	23,2
PH5 THREEPHASE	NO	12	3	6,5	42
PH5 THREEPHASE "DUAL SPEED"	YES	0-24	5,5	20	40
H5 THREEPHASE	NO	20	4	9	58

NOTES: (*) Other values on request
VFC: Variable Frequency Converter / Inverter

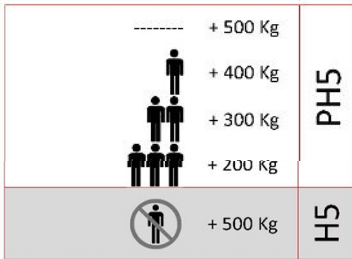

Mast section compatible with:

- E05 P&M Hoist
- E10 P&M Hoist
- PH5 Transp.Platform
- H5 Material Hoist
- PH10 Transp.Platform
- PH10 PLA/P TWIN Transp.Platform
- PH10 PLA/T TWIN Transp.Platform
- H10 Material Hoist
- P25 Single Mast Climber
- P25 Twin Mast Climber

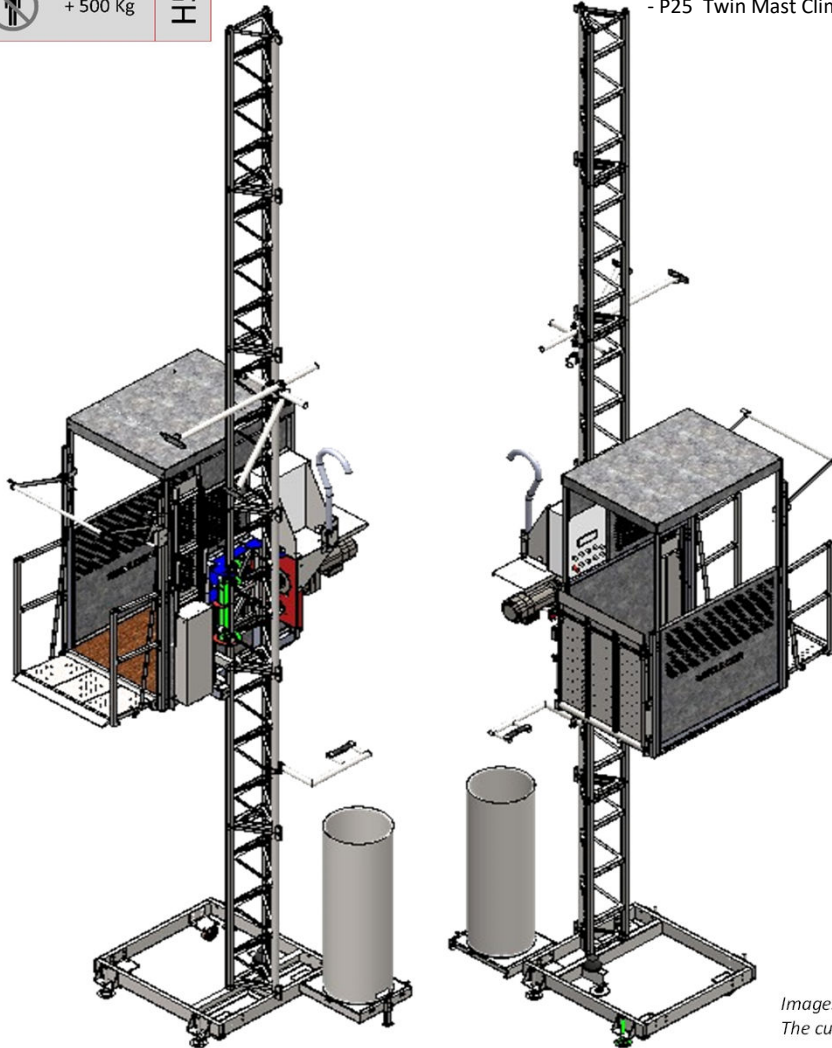
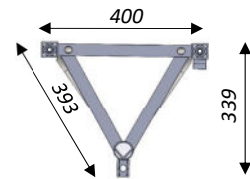

Images shown are only indicative
The customer can choose the preferred configuration

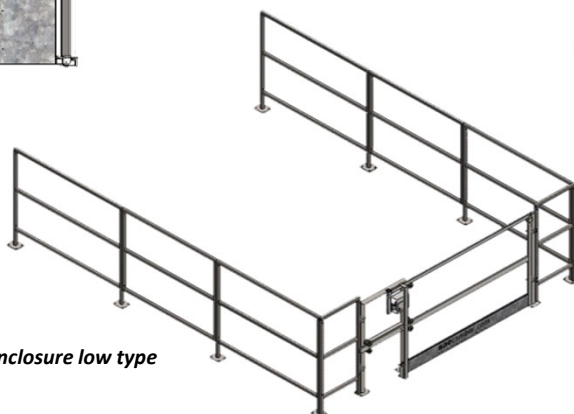
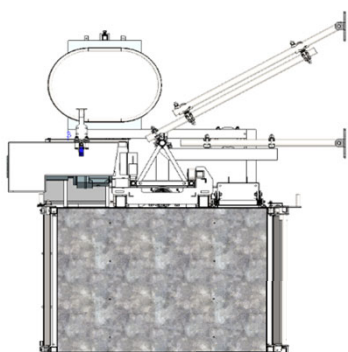
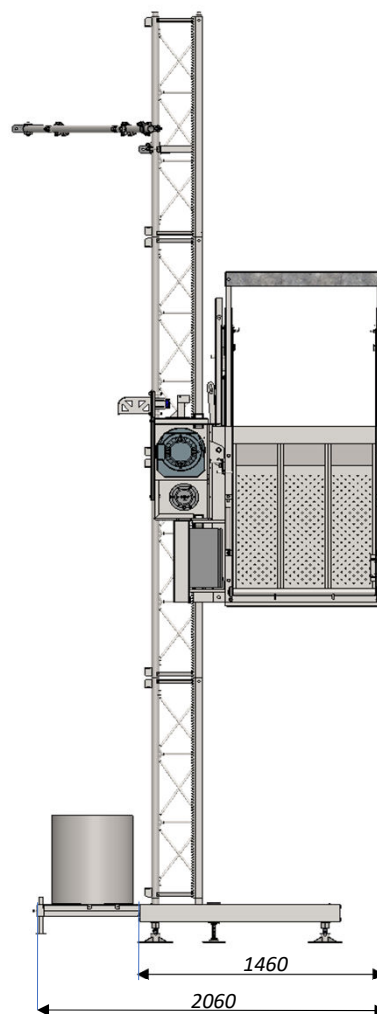
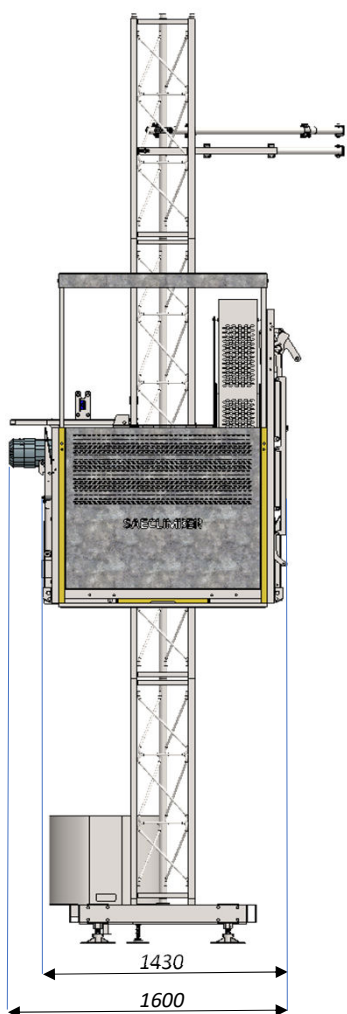

Ground enclosure low type

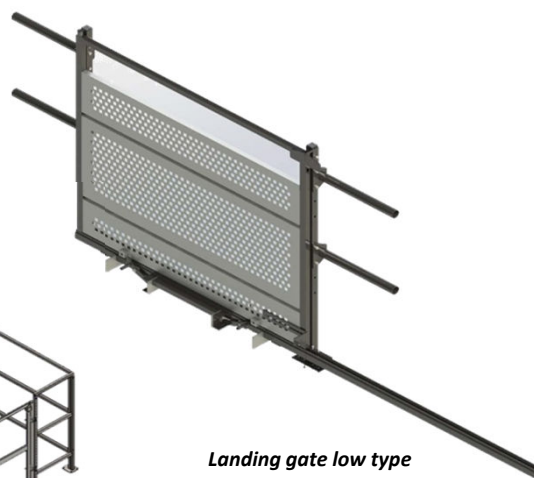

Landing gate low type

The Manufacturer reserves the right to change any of the above data without notice